

SCHEDULE OF ITEMS	
ITEM NO.	DESCRIPTION
1 & 2	REFER TO DRAWING 17
3	ISOLATING VALVE, IF BUTTERFLY VALVE TO BE GEAR SHUT TYPE (RESILIENT SEATED)
4	SPACER 5 x PIPE DIAMETER
5	MAGNETIC WATER METER, SUPPLIED BY WESTERN WATER, DIRT BOX NOT REQUIRED
6	SPACER 3 x PIPE DIAMETER
7	TESTABLE APPROVED SINGLE SPRING LOADED CHECK VALVE
METERS 50MM AND ABOVE TO BE INDEPENDENTLY SUPPORTED FROM PIPE WORK	

STANDARD LEGEND	
×	V Valve
○	M Meter
□	D.B Dirt Box
—	S.P. Straight Piece
⊥	T.F. Testing Ferrule
▭	L.S. Line Strainer
≡	B.P.D. Backflow Prevention Device (Testable or Non-Testable)
Z	S.C.V. Single Check Valve
⊥	T.D.C.V. Testable Detector Check Valve

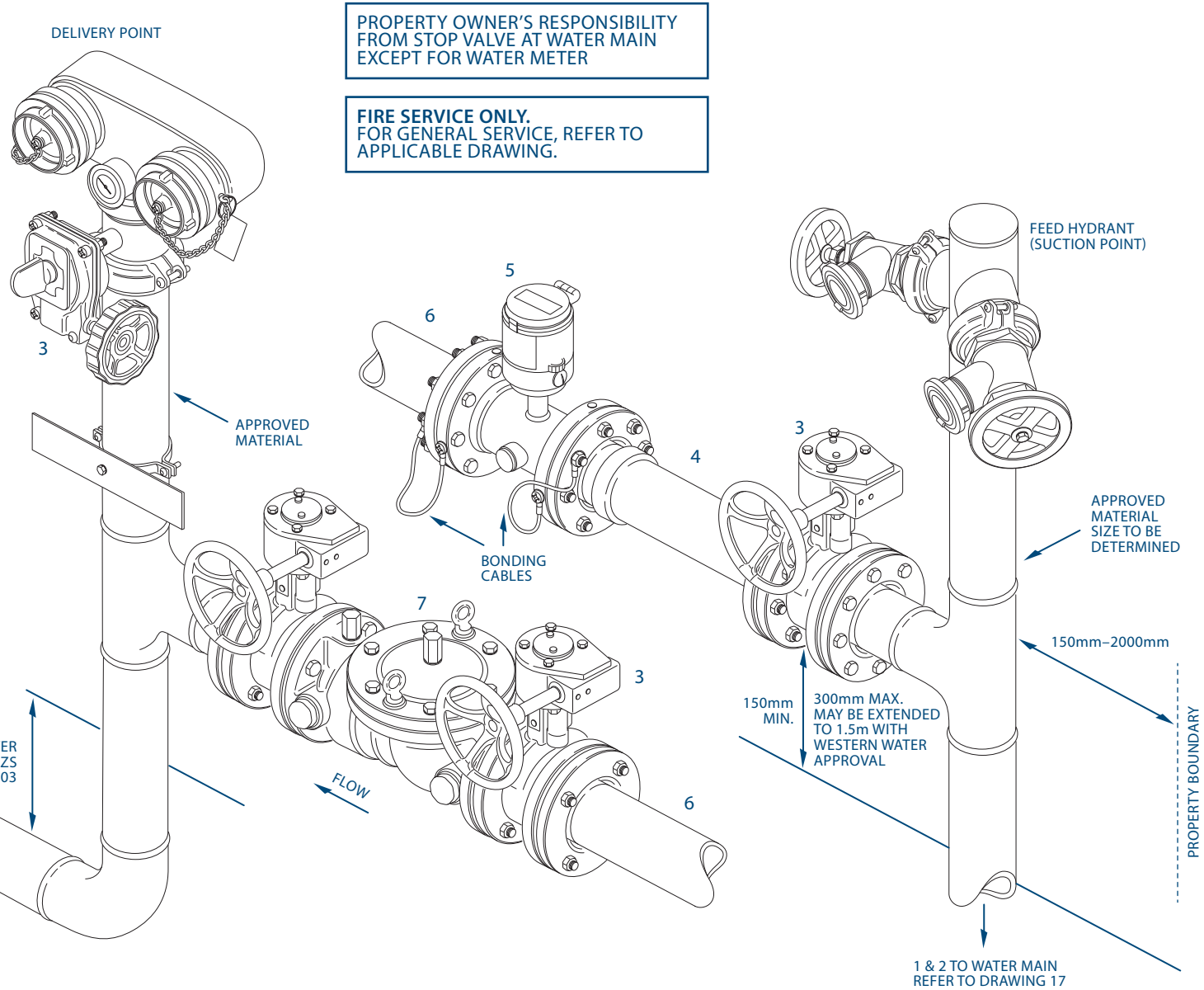

PROPERTY OWNER'S RESPONSIBILITY FROM STOP VALVE AT WATER MAIN EXCEPT FOR WATER METER

FIRE SERVICE ONLY. FOR GENERAL SERVICE, REFER TO APPLICABLE DRAWING.